

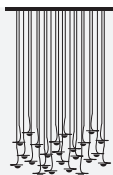

Chandelier Jackie O
with jack connection and satin steel base

chandelier



ISTRUZIONI DI MONTAGGIO / ASSEMBLY INSTRUCTIONS / INSTRUCTIONS DE MONTAGE / MONTAGEANLEITUNGEN / INSTRUCCIONES DE MONTAJE

I AVVERTENZE

- Si raccomanda che l'installazione venga eseguita da un elettricista abilitato.
- Togliere la tensione di alimentazione prima di effettuare l'installazione e per interventi di manutenzione o in caso di cattivo funzionamento.
- Si consiglia l'utilizzo dei guanti in dotazione. Per la pulizia della superficie utilizzare un piumino rimuovi-polvere.
- La lampada acquistata è garantita se installata e utilizzata nel rispetto delle specifiche del modello. Catellani & Smith declina ogni responsabilità per installazione non appropriata e/o uso diverso da quello indicato.
- La sorgente luminosa di questo apparecchio deve essere sostituita esclusivamente dal produttore, dal suo servizio di assistenza o da personale qualificato equivalente.

GB WARNINGS

- Only a qualified electrician should execute the installation.
- Switch off the power supply before installing, servicing or in case of malfunctioning.
- We suggest you to use the gloves provided. We recommend using a feather duster to clean the surfaces.
- The purchased lamp is guaranteed if installed and used in accordance with to the specifications of the model. Catellani & Smith is not responsible for inappropriate installation of the product and/or a different use than the one indicated.
- The lighting source of this appliance must be replaced by the manufacturer, by its technical service or by qualified electrician.

tensione di rete / voltage	<input type="checkbox"/> 220-240V	<input type="checkbox"/> 110V	<input type="checkbox"/> 110-240V		
LED / LED	<input type="text"/> x LED 1W				
driver / driver	24V constant voltage driver				
dimmerazione / dimming	<input type="checkbox"/> IGBT/Triac	<input type="checkbox"/> 1...10V	<input type="checkbox"/> PUSH	<input type="checkbox"/> DALI	<input type="checkbox"/> NO

layout n.

quality check n.

I	IP20				
classe class	classe di protezione protection class	persone suggerite per il montaggio people required for mounting		MADE IN ITALY	

BASE IN ACCIAIO SATINATO / SATIN STEEL BASE



quadrata / square

30x30 cm

60x60 cm



rotonda / round

Ø 40 cm

Ø 78 cm



rettangolare / rectangular

90x30 cm

150x30 cm

150x60 cm

custom / custom

cm

NB.

Ogni Jackie O è piegato singolarmente a mano: una tolleranza di max 15 mm sulle lunghezze cavo indicate è da considerarsi accettabile.
Each Jackie O is manually bent: a tolerance of about 15 mm on the given cable lengths is considered acceptable.

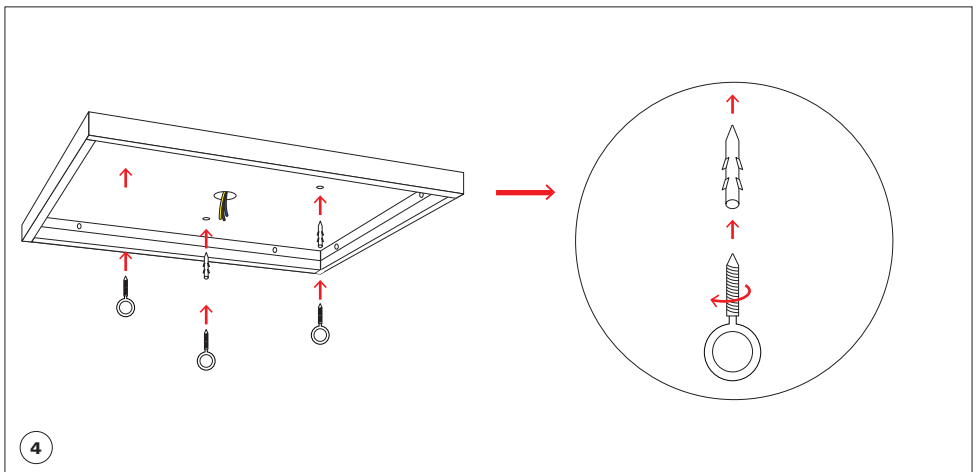
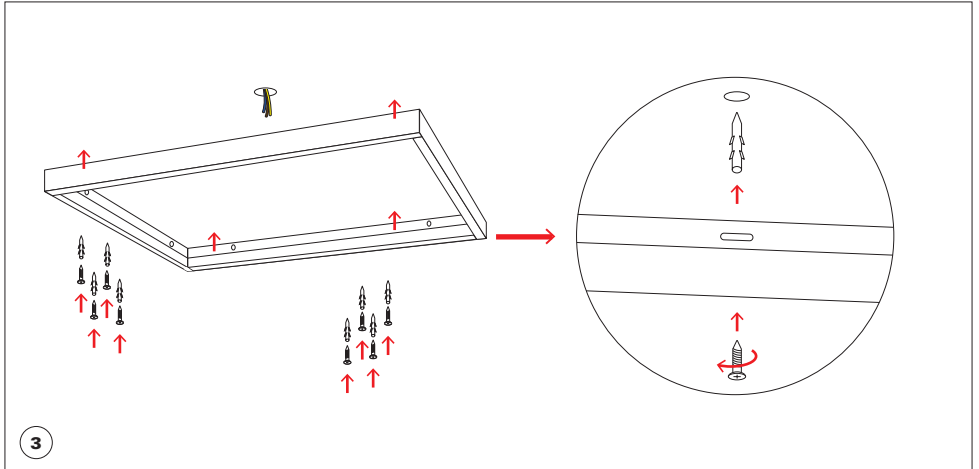
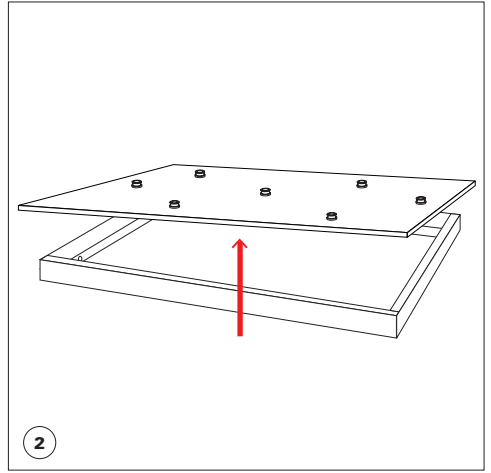
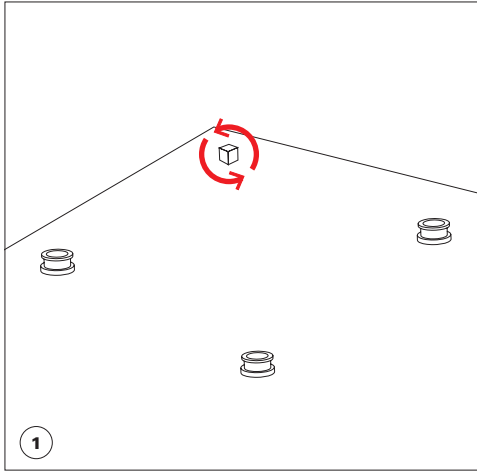

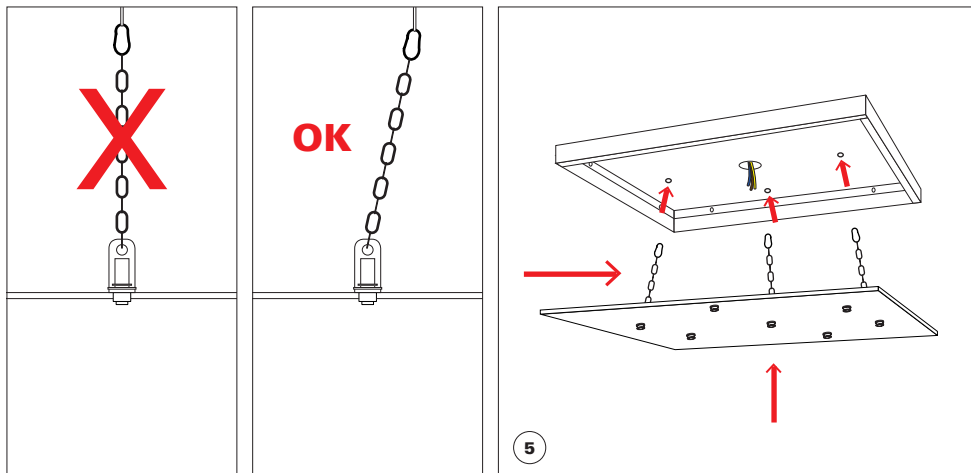

PER RAGIONI DI SICUREZZA, SI CONSIGLIA DI SPELARE IL CAVO PER MAX 7 MM.
 FOR SAFETY REASONS WE SUGGEST NOT TO UNSHEATH THE WIRE MORE THAN 7 MM.

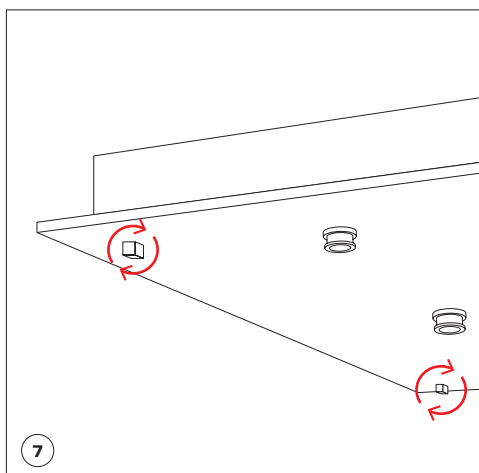
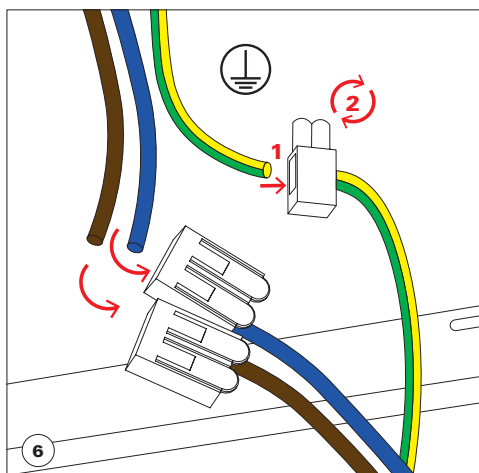
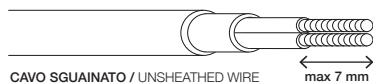

ATTENZIONE

togliere la tensione di alimentazione prima di connettere o disconnettere il jack.

WARNING

switch off the power supply before connecting or disconnecting the jack.

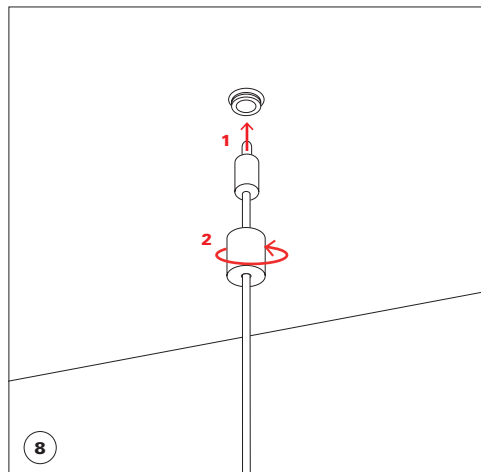

montare pendenti insacchettati/ keep the pendants packed during installation

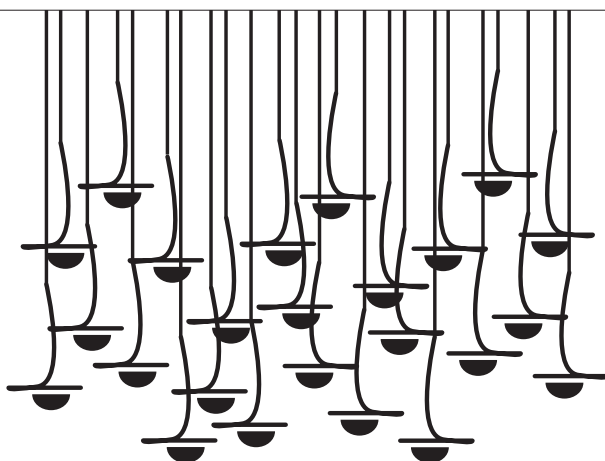
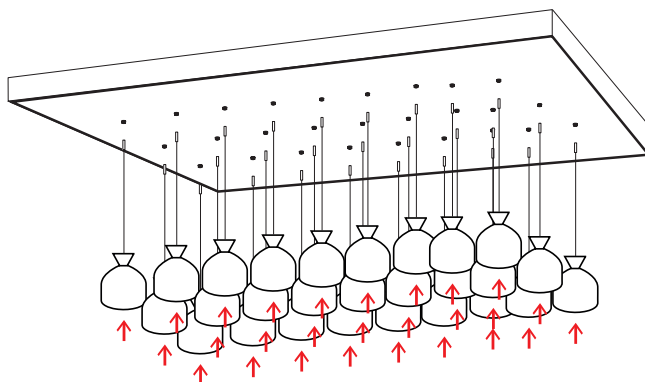

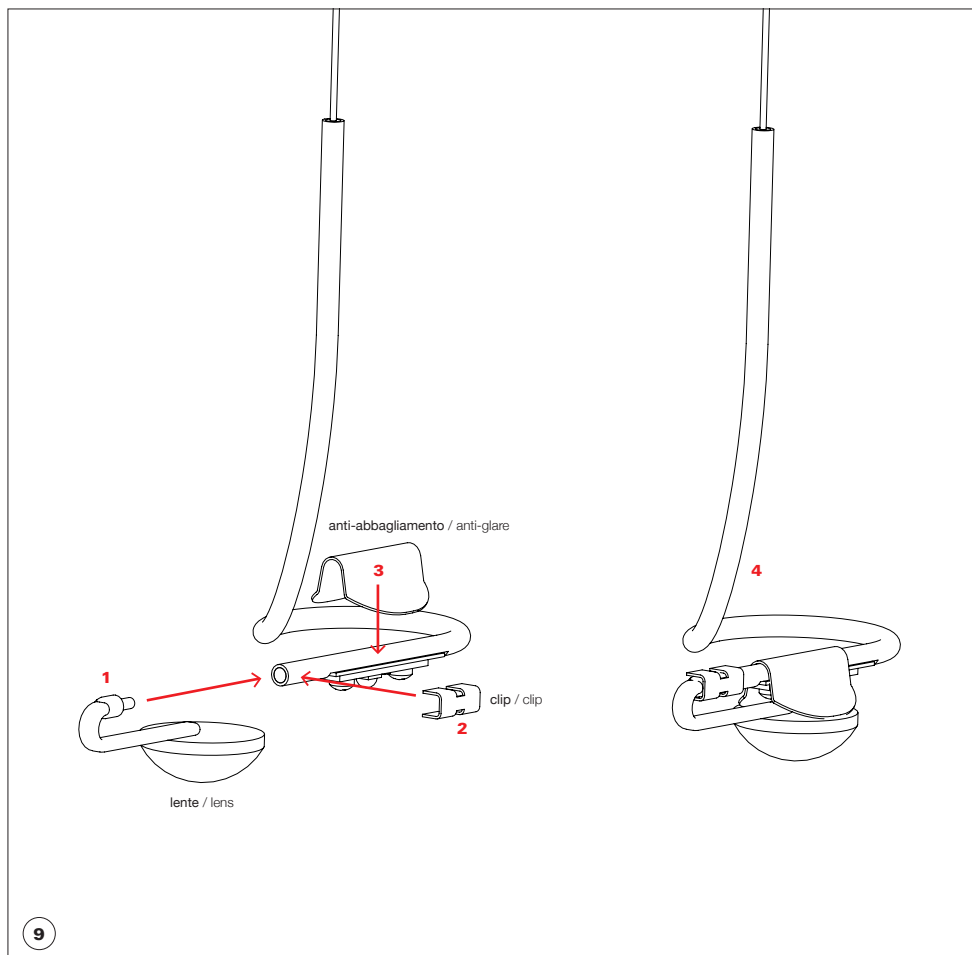

ATTENZIONE:

i componenti indicati nei disegni possono variare
per quantità e forma a seconda del modello

WARNING:

the components mentioned in the drawing may vary in quantity
and shape according to the model.



updated 06/2023

Questa apparecchiatura non deve essere smaltita come un normale rifiuto urbano, ma deve essere portata nel punto di raccolta appropriato per il riciclaggio di apparecchiature elettriche ed elettroniche. Provvedendo a smaltire questo prodotto in modo appropriato, si contribuisce ad evitare potenziali conseguenze negative per l'ambiente e per la salute umana, che potrebbero derivare da uno smaltimento inadeguato del prodotto. Per informazioni più dettagliate sul riciclaggio di questo prodotto, contattare l'ufficio comunale, il servizio locale di smaltimento rifiuti o il rivenditore presso il quale è stato acquistato il prodotto.

This equipment may not be treated as household waste. Instead it shall be handed over to the applicable collection point for the recycling of electrical and electronic equipment. By ensuring this product is disposed of correctly, you will help prevent potential negative consequences for the environment and human health, which could otherwise be caused by inappropriate waste handling of this product. For more detailed information about the recycling of this product, please contact your local city office, your household waste disposal or the dealer where you purchased this product.

